

Operating and Commissioning Instructions for BLR-CM

Contents:

- | | |
|--------------------------|-----------------------------------|
| 1. Installation | 6. Optional Parameters |
| 2. Connection Diagram | 7. Alarm Signals |
| 3. Functioning Principle | 8. Indication of measuring Values |
| 4. Commissioning | 9. Cancelling of memorized Data |
| 5. Standard Parameters | 10. Data Transmission |

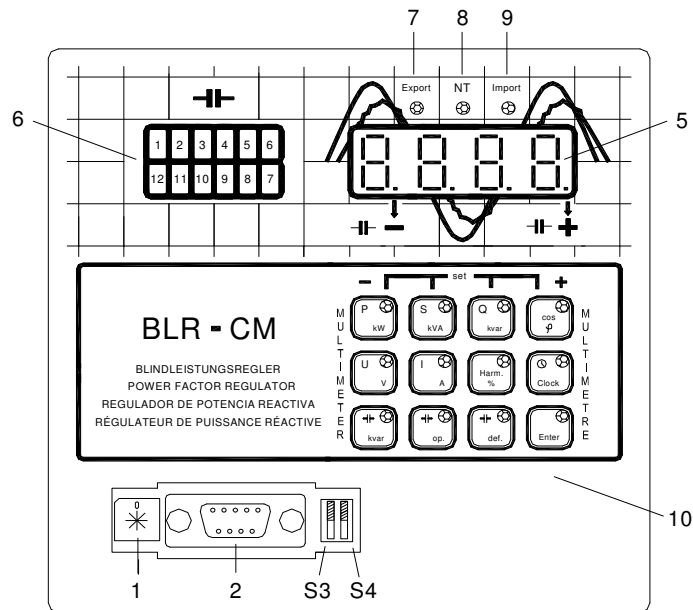

1. Installation

As with all electrical equipment, the appropriate specifications governing electrical installation must be followed when power factor correction equipment is installed. When removing the front nameplate to adjust the function switch and DIP switches, always ensure that your body is not carrying any electrostatic charge. This can be accomplished by simply touching an grounded object, such as the switchboard metal casing to dissipate any electrical charge before removing the cover plate.

1. Check that the measurement and control voltage, supply frequency and current transformer rating comply with the ratings given on the back of the relay.
2. Mount the relay in the switch panel:
either by means of two fixing bolts (standard), or:
by means of two side mounting right angled brackets (optional)
3. Connect up in accordance with the wiring diagram. **Pay special attention to the cross section size of the C.T. connections. We recommend for runs up to 10 metres 2,5 mm² cross section.**
4. An integrated voltage observation in BLR-CM guarantees a safety-disconnection of the capacitors in case of excess voltage < 70% of mains voltage.
5. For voltage observation connect terminal **A** to phase **L2 (B)** or **L3 (C)** alternatively (see wiring diagram). This ensures to disconnect all components of the capacitor bank in case of decreased voltage < 70% .

2. Connection Diagram

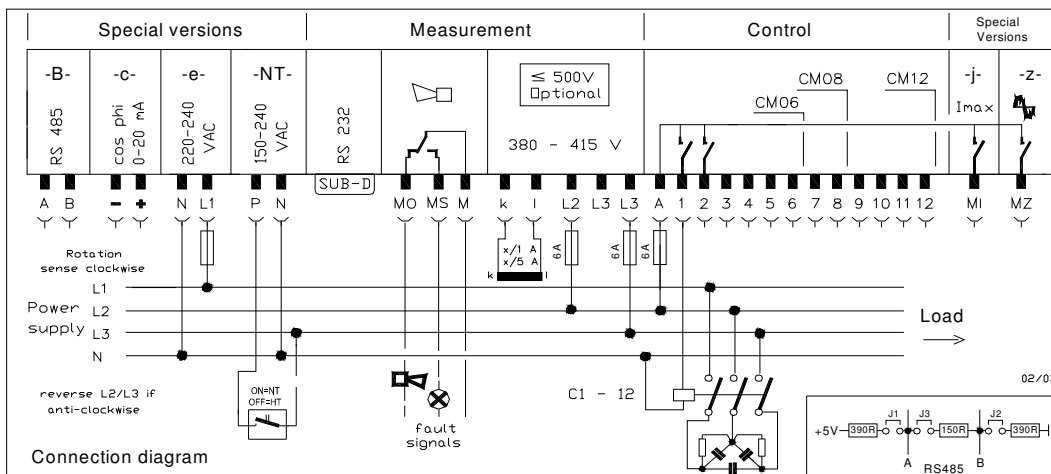

3. Functioning Principle

The individual functions of selection switch (1) are listed with character **H..** as sign (e.g.: **H2** = switching time).

The measuring system has been designed with the phase in which the c.t. is integrated is by standard the phase L1. The two other phases L2 and L3 are connected in a clockwise rotation sense to the relay.

When installing the BLR-CM, a C/k-threshold no longer has to be entered. The relay measures the connected capacitors during the daily regulation process according to their compensation impact, memorizes the values, and then compensates deviations from p.f.target using the memorized values..

By way of entering the c.t. ratio factor (**H6**) it is possible to display the measuring values. All preset parameters and controlled variables remain unaltered even in case of a system failure.

4. Commissioning

All regulators are preset to the following parameters at the factory:

Standard:

H0	Identification number = 0 (for bus mode)
H1	1.p.f. target set $\cos \varphi = 1,00$
H2	switching time delay per step = 40 s
H5	step limitation acc. to type of relay (6/8/12)
H6	c.t. factor = 100
H7	v.t. factor = 1,00
H8	Alarm mode = 0
H9	regulation programme = automatic

Optional

HA	2. p. f. target set $\cos \varphi = 1,00$
HB	asymmetric. switching time factor = 1
HC	load reversal switching time delay = 30 s
HD	capacitor max. rating defective = < 50 %
HE	current max. rating = 0
HF	Time = CET (central European. time)

H3 Automatic function – fully automatic control of compensation plant

H4 Manual operation

This mode is activated by the **ENTER** switch. In the three operating keys LEDs flash. The key symbols "cos φ " (+) enables to connect, and the key "P" (-) to disconnect steps. Decimal dots in the display above the symbols "+" and "-" flash to indicate that the switching time delay runs (see page 5 - H4).

In order to re-activate automatic compensation the selection button must be put in position H3 again.

All parameters preset on the relay can be adjusted locally when required by means of selecting button. Precondition is that a voltage potential is applied to the relay. Please proceed as follows:

Select alteration mode by turning to the appropriate switch position (H-Position). The memorized value is shown on the digital display. Adjust the value by pressing – **Enter** - and use the first (upper) set of keys (2 or 4 respectively - the corresponding LED's will flash) to enter the required new value (0-9 as shown on the digital display. To confirm and activate please press the button **Enter** again. **Attention! If adjustments are not confirmed by Enter, the old value remains stored in memory!** If the Enter mode is not confirmed within a period of 3 minutes it is automatically closed.

- Apply the measurement and control voltages. Connect the current transformer, and remove any short circuit link. When commissioning the display is first dark, after 6 seconds a self test of the optical devices in the display and the keyboard follows which lasts 2 seconds. The measuring value indicated is the system power factor $\cos \varphi$, other values can be displayed by means of pressing the appropriate button.
Indication "I—0": no current is flowing, < 15 mA of secondary c.t. current is required.
- A pre-adjusted lock-out time prevents any switching operation for a period of 90 s. The elapse of this time is indicated by oscillation of the two decimal dots above the display symbols "+" and "-". After the lock-out time the dot in the right-hand display "+" will flash, in the presence of inductive load, if relay is connected correctly.
- Adjust DIP (coding) switch to select alarm function ON (in circuit) or OFF (out of circuit) (if required, adjust memory mode in **H8**)
S3 = power factor alarm
S4 = harmonic alarm
- Entering the number of connected capacitor steps under **H5** (display shows **CL_3** = Capacitor Limitation – step 3). If the max. number of steps is selected, but capacitors are not connected to all steps, the relay will recognize this, and will make three switching attempts to verify there is no connection. The disconnected step(s) will then be excluded from the switching sequence. The number of disconnected steps is able to be indicated by pressing the > **def** < button. The disconnected steps will be automatically reactivated and a renewed switching attempt will be made after a period of 1 days or after a system power failure.
- c.t. factor "k" to be adjusted in **H6** (f. ex.: 500 A/5 A = factor 100 or 1000 A/1 A = factor 1000). If a summation transformer is employed the individual transformer values are added to receive the total factor, (e.g.: 1000 A/5 A + 1000 A/5 A + 1000 A/5 A) x (5 A + 5 A + 5 A/5 A) = (3000 A/15 A) x (15 A/5 A) = (200 x 3) = k = factor 600. Please note here that whenever measuring values are indicated these are always total values of the entire plant.
- If required, adjust voltage factor in **H7** (only when operated in medium voltage systems)
- With the **H8** button it is possible to select two types of low power factor alarm memory: The selecting process is started by <**Enter**> and can be altered by switching "+" or "-". The display changes accordingly from 0 to 1. To reconfirm please press <**Enter**> again. (Both functions are discussed further in chapter 7 (a) (d) (f)).
- During commissioning the relay switches – following the selected switching time delay - steps successively until the target power factor $\cos \varphi$ (**H1**) is attained. Each energized step is indicated on the LED display (6). As each step switches in, so the digital display of power factor will change. If the actual p. f. deviates from the target $\cos \varphi$, the "+" dot (below target) or the "-" dot (above target) will flash. In the course of a so-called "finding process" every

individual capacitor is switched in circuit to judge its size. The finding process is over when the power per capacitor has been evaluated. The values remain memorized even in case of a system power failure. A new finding is actuated only if the capacitor size values are cancelled deliberately (see chapter 9).

A flashing of the decimal dots in the display indicates that the relay has found a suitable unactivated capacitor which will be switched in circuit after elapse of the switching time delay (H2). If capacitors of different sizes are operated in the appropriate combination of required amounts of power (kvar), the compensation to meet target p.f. will be attained by automatic connection and disconnection of already energized steps.

- (i) When changing over from automatic mode (H3) to manual mode (H4), steps will be switched in / out respectively by pushing key **cos (+) / P (-)** in rotational switching program "first in - first out".
By changing back into automatic mode, all activated capacitors will be switched off **at once** after preset switching time delay (H2). Afterwards automatic control will start again.
- (j) The BLR-CM's variable load reversal lock-out time (30 s) is activated when switching direction changes from "up" to "down" or vice versa. This switching time is indicated by dots "+" and "-" oscillating simultaneously and has been designed to ensure that the capacitors are able to discharge. Local parameter setting is available in position HC.
- (k) The two LED's Import and Export above the display indicate the direction of energy at the measuring point. Export means feedback of active/reactive energy (capacitive) into the local system, and Import consequently means consumption of the same.
- (l) An automatic data log of the measuring values results in a brief extinguishing of the display (no reset!).

Once the required settings or alterations have been made, set function switch (1) to position H3 "automatic" and replace the front cover plate, so as to inhibit unauthorized interference with relay settings.

5. Standard Parameters

Coding switch (S3)

Relay alarm signals

Switch position OFF = alarm signals off – cancel alarm (reset)
 ON = alarm signals on

Coding switch (S4)

Harmonic alarm

Switch position OFF = signal off, respectively: cancel alarm (reset)
 ON = alarm signals on

Function switches (1)

H0 = Relay not in automatic function. All steps switched off in accordance with the selected step switching time.
Digital display will show: **"OFF"**
Set for Identification Number for bus mode

H1 = Adjustment of pre-set target p. f. within the range 0,70 lag ... 1,0 ... 0,90 lead by means of
<Enter; +/-, Enter> Target level is shown in the display.
Relay continues to operate automatically.

H2 = Adjustment of the step switching time – min. 3 sec. up to 9999 secs.
<Enter; 4 individual buttons, Enter> Adjust digitally in strict accordance with value given on the above display.
During this setting, relay continues to compensate automatically.

H3 = Relay in automatic operation, with indication of system p. f. or other measuring values.
If +/- dots are flashing, this indicates that the target p. f. has not been achieved.
A suitable capacitor size will be selected.

H4 = Manual operation.
<Enter; +/->selectable.
The display will show **H** flashing with the selected measuring value flashing alternately.
Capacitor steps can be switched on/off in rotation after elapse of the selected step switching time using the +/- buttons, respectively.
Automatic regulation has no impact!
Return to automatic operation mode by change from **H4**⇒**H3**. Consider, first of all any activated steps will be disconnected at once before starting in automatic mode from the very beginning!

H5 = The number of switching steps can be predetermined, using <Enter; +/->Enter>
Digital display will show alternately the number of steps and the predetermined measuring value;
for ex. for 10 steps: **"CL10"** (CL = Capacitor Limitation).
Do not exceed the existing numbers of control outputs!
Automatic regulation is continued.

- H6 =** Input of c. t. factor (see page 3, item e)
<Enter; 4 individual keys, Enter> Adjust digitally in strict accordance with value given on the above display.
Automatic regulation is continued.
- H7 =** Input of voltage transformer factor, if required, standard = 1,00 (= nominal voltage of the relay)
<Enter; +/-, Enter> adjustable.
Please refer to digital display.
Automatic regulation is continued.
- H8 =** Selects the mode of alarm signal required.
<Enter; +/-, Enter> adjustable
Please refer to digital display.
If the display shows "A_0", the alarm is stored in the memory and can only be cancelled by briefly actuating DIP switch S3.
If the display shows "A_1", the alarm will be cancelled automatically, when the preset target p. f. level has been attained again (e.g. load reduction or any change of switching direction up/down or vice versa).
If requested data are not indicated on the order, the relay will be supplied in "A_1" mode.!
- H9 =** Pre-adjustment of switching programme (necessary when relay is operated in filter circuits).
<Enter; +/-, Enter> adjustable.
Please refer to display.
- | | | |
|--------------|-------------------------------------|---------------------------------------|
| 1) "auto" | fully automatic switching operation | (not applicable for filter circuits) |
| 2) "1:1:1:1" | capacitors' ratio 1:1:1:1..... | (up / down – no rotational switching) |
| 3) "1:1:2:2" | capacitors' ratio 1:1:2:2..... | |
| 4) "1:2:2:2" | capacitors' ratio 1:2:2:2..... | |
| 5) "1:2:3:3" | capacitors' ratio 1:2:3:3..... | |
| 6) "1:2:4:4" | capacitors' ratio 1:2:4:4..... | |
| 7) "1:2:4:8" | capacitors' ratio 1:2:4:8..... | |
- In all programmes (except for "auto") it must be ensured that all capacitor sizes comply with the mentioned ratios! Automatic detection and indication of capacitor size is limited to the 1st capacitor, assuming all following capacitors will comply with the selected switching programme (3-7)! Detection of failed capacitors is not possible!**
- HB =** Input of asymmetrical switching time delay.
Using <Enter; +/-,Enter>, adjustable between 0 ... 50.
Example: if the display shows "Y 10" the factor displayed will multiply the switching time;
e. g. 10 = 10 x the preset switching time (from "H2") for disconnecting steps.
(rapid switching on – slow switching off)
- HC =** Rapid contactor switching rate limiter; selectable between 0...255 s.
Using <Enter - 4 individual buttons +/-, Enter>; adjust required value (in seconds) to show to proper value on the display. Display shows e.g.: "L 30". In case of reversed switching direction (connect/disconnect, or disconnect/connect, respectively) this lockout time is added to the selected switching time between steps. This helps to prevent the rapid on/off switching of a contactor on a constantly changing load, and to ensure the capacitors to be discharged completely.
- HD =** Input of a threshold – loss of capacitor power – defect signal
<Enter - 4 individual buttons +/-, Enter>; adjust required value to show on the display.
Digital display shows e.g.: 60. This implies that if the capacitor power (per step) falls below 60 % of the original value the relay triggers an alarm signal (see chapter 7b).
An external signal is triggered via the standard alarm relay integrated in the controller
- HE =** Input of a thermal current threshold value – apparent current I_{max}. – overload alarm contact
<Enter - 4 individual buttons +/-, Enter>; adjust required value digitally parallel to the display above.
Adjusting range: 0 – 9999 A (0 = no function)

6. Optional Parameters:

- HA =** Input of second target power factor level for low tariff operation.
Setting range 0,70 lag ... 1,0 ... 0,90 lead. **Option – NT -**
The required target level is adjusted in the display using <Enter; +/-, Enter>.
Please refer to digital display.
In order to activate this feature a supply voltage of 150-240 V AC must be applied to terminals P-N.
(Using a time switch, radio controlled relay etc.) LED (NT) will illuminate if this feature is active.
(contacts M – MO close).
- HE =** Input of a thermal current threshold value – apparent current I_{max}. – overload alarm contact **- Option j –**
<Enter - 4 individual buttons +/-, Enter>; adjust required value digitally parallel to the display above.
Adjusting range: 0 – 9999 A

- If preset value is **0** this function is off service.
 An external fault signal is triggered by a relay integrated in the controller (contacts **A – MI** will close).
- HF =** Date & time adjustment & record **- Option D –**
 This adjusting mode operates on three levels and can be started by
 <Enter; 4 individual buttons +/->
 <Enter; display shows year in 4 digits e.g.: 2000
 <Enter; display shows day / month e.g.: 26.01.
 <Enter; display shows hour / minute e.g.: 15.45
 Leave from this mode by again pressing <Enter>.
 Any measured data or switching operations may be stored internally and read out via software-visualisation
 “**CMWin**” in tables for analysis.
 If this option is not integrated display shows: >**no_t**<

Additional Options:

- **e** - Single phase measurement L1(A) /N - c.t. sensing in L1 (A).
- **z** - Harmonic alarm relay closes across terminals A – MZ (see chapter 7/d).
- **c** - Analogue output with reference to $\cos\phi$. Proportional to phase angle deviation ϕ on terminals + and – a DC – current is available. There are 3 ranges selectable: 0-20 mA / 0-24 mA / 4-20 mA. Selected range must be mentioned in purchase order. Local selection is not possible. Indication is running from –60° (leading side) 0° +60° (lagging side) with maximum current.
- **t** - This version contains transistor outputs to control thyristor modules for rapid operation.
- **B**- Interface RS 485 for data transfer terminals A / B.
- **MB**- Modbus connection via interface RS485

7. Alarm Signals

Alarm mode is activated by means of the two coding switches **S3** for power factor alarm and **S4** for harmonic alarm. Alarm signals are triggered whenever a malfunction in the regulation process of the compensation system has been detected, or if permissible threshold values are exceeded.

The different alarm signals (2 s) are given alternately with the selected measuring function (5 s) on the digital display.

(a) **Power factor alarm** (Display shows: **ALLo** / **ALHi**)

This alarm mode supervises under-/overcompensation of the system.

During manual operation this safeguard is by standard not active, because the client can regulate a power value which does not correspond with the actual load situation.

In case of undercompensation the display signals “**ALLo**”. If the predetermined power factor is not obtained due to insufficient capacitance, the alarm signal is triggered after elapse of 75 x the selected step switching time.

In case of overcompensation the signal issued is: “**ALHi**”. If the set target p.f. is still surpassed due to overcompensation (welded contacts) after elapse of 75 x the selected step switching time, this alarm will be triggered.

External signal is issued by the relay **–m-** (contacts **M–MO** close). If manual reset has been predetermined (**H8** set to 0), the alarm signal is recorded until it is cancelled manually: To do this briefly, put coding switch **S3** in **OFF** position or press key **cos φ** for more than 10 seconds. Automatic reset (**H8** set to 1) is triggered in case of reverse of switching direction (**ALLo**: connection ... disconnection, and consequently **ALHi**: disconnection ... connection)

(b) **Loss in capacitor step (kvar) output alarm** (Display shows: **ALnn**)

This alarm function observes the loss in compensation power of the individual capacitors when in operation. Calculation basis is the capacitor size recorded during commissioning (original value, can be verified by means of key “**kvar**” – digital display shows: **F.**). If the actual capacitance falls below 50 % of the original value (verify by means of key “**kvar**” – digital display shows: **L.**), the loss in capacitance is signalled by “**ALnn**”, **nn** stands for the number of the defective capacitor e.g.: **AL12**. If more than one step is affected, each of the capacitors is referred to individually by a rolling fault signal.. Preset parameter setting is available in position **HC**.

The external signal is triggered by relay **–m-** (contacts **M – MO** close).

The signal is cancelled as soon as the threshold is surpassed again (automatic reset function).

Coding switch **S3** in **OFF** position resets any triggered alarm. Failed capacitors will be sensed out again.

(c) **Defective capacitor step alarm** (Display shows: **ALCd**)

This alarm mode observes any default of capacitor steps.

To call up the defective steps press key “**def**”. If more than one capacitor fails, each step affected is automatically reported in the alternating indication on the display.

An external signal is triggered by relay **–m-**(contacts **M – MO** close).

The alarm is cancelled in case of brief interruption of voltage supply, to do this: actuate key “**def**” longer than 10 seconds, or automatic cancellation in a 1 day rhythm.

By setting coding switch **S3** in **OFF** position, the signal is no longer visible, however it remains active in the background.

(d) **Harmonic overload alarm** (Display shows: **ALHA**)

This alarm function observes the harmonic content of the line voltage. External signal is triggered by the relay **–z-** (contacts **A – MZ** close).

If reset is determined to be done manually (**H8** setting = 0), the alarm signal remains to be recorded until cancellation by briefly setting coding switch **S4** to **OFF** position or by pressing key **Harm.%** for more than 10 seconds.

If automatic reset has been selected (**H8** setting = 1), the signal is automatically cancelled when in the subsequent time window (in 8 minute intervals) the harmonic load is below the preset value.

(e) **Overcurrent** (display shows: **AL I**)

This function is only actuated if a value > 0 is entered under **HE**.

Overcurrent is indicated as soon as the measured current **I** exceeds the preset threshold in **HE**. The signal is cancelled as soon as the current amount no longer exceeds the threshold. (automatic reset, optical function only).

(f) **Thermal overload** (display shows: **ALdI** - optional)

This alarm mode is triggered if the thermal current load exceeds the value preset in **HE** (bimetal principle, time window 8 minutes)

In addition, there is an external signal issued by relay -j-. (contacts **A – MI** close).

If reset is determined to be done manually (**H8** setting = 0), the alarm is recorded until it is manually cancelled as follows: Press button "I" longer than 10 seconds.

An automatic cancellation of the alarm signal (**H8** setting = 1) follows if in the subsequent time window (8 minute intervals) no renewed alarm has been triggered.

8. Indication of measuring Values

Key: A keypad enables you to indicate measuring values and/or functions:

P = total active power in kW (basis: symmetrical load)

S = total apparent power in kVA (basis: symmetrical load)

Q = total reactive power in kvar (basis: symmetrical load)

cos φ = The digital display shows the system power factor $\cos \varphi$
(e.g.: 1 0,87 for inductive or c 0.94 for capacitive load)

U = system three phase voltage in V (delta voltage)

I = apparent current and maximum demand (measuring phase)
Rolling display of thermic current – I_{th} (Bimetal function – time display = 8 min.)

Harm. = Activation of fourier analysis of the system voltage
% Indication of harmonic content of the 3./5./7./9./11./13. Harmonic in % of the basic frequency by one push each on the key. The change in selected harmonic is automatic e.g.: **5** (Harm.) and **1.2** (%), each remains visible for 3 s.

Clock = Call-up date & time (only with Option – D -)
By one push each on the key the display changes from "yyyy" = year to "dd.nn" = day.month, and then to: "hh.mm" = hour.minute etc.
In case the relay does not include this option, the display shows: "no_t".

--||-- = The different capacitors sizes are given in kvar.

kvar By one push each on the key, display changes to the next step. For each step automatically two different values are given alternately e.g.:

"2 L" (**L**ast) referring to capacitor 2, display shows alternately the actual capacitor size in kvar and

"2 F" (**F**irst) referring to capacitor 2, the capacitor size at the first time of commissioning in kvar.

--||-- = Inquiry of switchings per step.

op. Automatic change of display regarding number of steps and switchings
By pressing the key next step is indicated.

--||-- = Display of defective capacitor steps

def. Several steps are shown in a rolling display.

Enter = Selecting and confirming parameter adjustments and activating of manual operation.

9. Cancelling of memorized Data

Following data can be cancelled by means of the appropriate keys:

Thermic display of current **I_{th}**

Press key **I** >20seconds

Capacitance per step in **kvar**

Switch off all capacitor steps!

The value **L...kvar**

Set selecting switch to **H0** and press **kvar** key longer than 10 seconds.

The value **F...kvar**

Set selecting switch to **H0** and press **kvar** key longer than 20 seconds.

When cancelling the relay sets all values simultaneously to 0.

Switching cycles per capacitor step

All values of the individual steps are reset simultaneously to 0 by pressing key **op.** longer than 10 seconds.

"Defective steps"

Any memorized "defective" capacitors may be cancelled by means of pushing key **def** >10seconds.

Searching for defective steps is prompted by net interruption, automatically in a 1-day-rhythm or after a manual reset.

When cancelling all values will be simultaneously set to zero.

10. Data Transmission

The relay contains an interface RS 232 (9-pole SUB-D) behind the removable nameplate for data transmission to a PC or a notebook.

BELUK-software "**CMSTO_E**" enables to indicate and memorizing of operation cycles, signed with clock and date on PC.

Relays including option "**D**" enable the storage of data with an internal data logger signed with clock and date. The internal data-logger is able to store up to 10.000 switching operations or measuring cycles, respectively. By using software "**CMWin_e**" (see special software instructions) memorized data may be read out, signed with clock and date. Data transfer runs via interface RS 232.

Option "**B**" stands for interface RS 485 (terminal on the rear), which enables you to transmit data over distance up to 1,2 km. "**CMWin_e**" enables either to read out any memorized data for analysis purposes or download amended parameters like target p.f. or switching time delay etc.

It is possible to implement our CM-relays into our own BELUK BUS System with min.2 units by using 2-pole screened data cable. Cable's terminating resistance must preset at CM relay, locally.
(see special software instructions – **CMWin_bus**).

Option "**MB**" (see separate instruction) contents an interface RS485 (terminals on backside of regulator) and enables data transmission up to 1,2 km.



ILLIMITE INC. email info@illimite.com
P.O. Box 876 web www.illimite.com
LOCKPORT, NY 14095 tel: 716-439-8600
fax: 716-439-9474

