

Power-Factor-Control-Relay BLR-CC



STANDARD FEATURES

- Automatic Self Adjustment to any Capacitors Step Value
- Digital Indication of Power Factor and Preset Parameters
- No-Volt Release Feature to immediately Disconnect all Capacitors in the Event of Power Failure .
- Plug-in Terminal Connection
- Digital Setting of Individual Parameters including Target Power Factor, Switching Time Delay, Step Limit, etc.
- Elimination of Defect Capacitor Steps (e.g. Welded Contactors)
- Visual Display of Control Alarm (cos)

OPTIONAL FEATURES

- Fault Signalling Contact (m) to Indicate Control Alarm

ILLIMITE IS YOUR
HEADQUARTERS
FOR ALL BELUK
POWER FACTOR
CONTROLLERS!

ILLIMITE
inc TOOLS FOR
TECHNOLOGY

ILLIMITE INCORPORATED
P. O. Box 876
LOCKPORT, NY 14095
tel: 716 - 439 - 8600
fax: 716 - 439 - 9474

WWW.ILLIMITE.COM
INFO@ILLIMITE.COM



TECHNOLOGY OF THE BLR-CC RELAY **Target Power Factor Setting**

Evaluation of the reactive load is achieved by taking instantaneous measurements in all four quadrants of voltage and current. These values are digitalised in the microprocessor and continuously evaluated so as to provide the active and reactive components. The value of $\cos \phi$ is calculated from these two values.

The recognition of the value of each capacitor step is achieved without unnecessary test switchings - based on those obtained in the daily routine of reactive load compensation. The first process on new installations is a "learning curve" of the value of each capacitor in the process of normal switching. If the actual reactive load deviates from the target power factor, then a "trial switching" will be made on the as yet unknown "Capacitor Step Values". It is no longer necessary to manually select the starting current - or C/k value. The value of each capacitor step will be evaluated by the relay and stored in its memory permanently, even if the voltage supply to the relay fails.

The relay will select from the bank of capacitors available the step(s) which are necessary in order to achieve the required level of reactive compensation. Fixed switching programmes are no longer required. The relay will automatically select from its memory the most appropriate capacitor step size to meet the reactive load demand.

Any subsequent loss of reactive power from any capacitor step will be recognized and evaluated. Total loss of reactive step output due to fuse failure for example, will be recorded in the relay memory as a defective step. Switching exits which are not connected or defective capacitor steps will be excluded from the regulation process. At weekly intervals, or each time the relay is re-energized, three attempts will be made to check any previously reported failed capacitor step. If the fuses have been replaced for example that step can then be brought back into the reactive compensation calculation.

There are two different types of the BLR-CC relay: BLR-CC 03 and 04 with 3 or 4 switched steps. If not all steps are required, a step limiting feature can be programmed on site.

Relay parameter setting (e.g. target p.f., switching time delay, step limitation) is enabled by means of function switch (3). This switch is located behind the removable nameplate that protects the relay against unauthorized manipulation.

The target $\cos \phi$ can be precisely selected in the range of 0.70 lagg. ... 1 ... 0.90 lead. using the +/- buttons (1 and 2).

Switching Time Delay

Using the +/- buttons the precise switching time can be selected within the range of 5 ... 1200 sec. For normal installations the switching time should not be less than 40 seconds per step. Shorter switching times can be selected when required. This is made possible by means of an integrated reactive load reversal switching time delay feature. This will provide an additional 30 sec. delay before any step which has just been switched off can be switched back on again. However, it must always be born in mind that shorter switching times will result in a higher switching rate and consequent wear on contactors etc.

Digital $\cos \phi$ Indication

In addition to regulating the reactive load the digital indicator (5) will show the instantaneous value of the system power factor. This is achieved by calculating the relationship between active and reactive load - a feature which is becoming even more important due to the normal occurrence of non-sinusoidal waveforms.

Switching by Hand

In manual operation mode capacitor steps can be switched in and out according to the selected switching time delay, using the +/- buttons. Only one depression is necessary. Once the required switching is achieved the next command is given.

No-Volt Release Feature

In the event of a power failure longer than 35 msec., the relay will immediately disconnect all capacitors from the supply. Once the supply is restored, there will apply a lock-out time of 90 sec. before the relay starts switching. This lock out time also applies on initial energizing of a new installation.

LED Indication of Capacitor Steps

The LED display (4) shows the status of each capacitor step.

Internal Fault Signalling ($\cos \phi$)

The BLR-CC relay incorporates a fault signalling alarm which will indicate, for example, if there are insufficient capacitors to achieve the target power factor. The letters "AL" will appear in the display, if monitoring is activated. The alarm will be triggered after a time delay of 75 times step switching time. The alarm operation is cancelled automatically once the power factor improves to the target level.

OPTIONAL FEATURES

Fault Signalling Contact (m) for Control Alarm (cos !)

An additional relay (m) can be fitted which will provide an extremely worthwhile additional feature to any Power Factor Correction Installation. According to the alarm "AL" in the display, the relay contact will close in the event of over- or under- compensation in relation to the target power factor. This can energize an acoustic or visual external alarm. If an external voltage source is available, this relay will also report if the power supply is lost to the capacitor bank.

This feature enables the relay to provide an early report of insufficient installed capacitance, or capacitor, fuse or contactor failure. This is far more cost effective than waiting until excessive reactive current costs appear on the electricity bill.

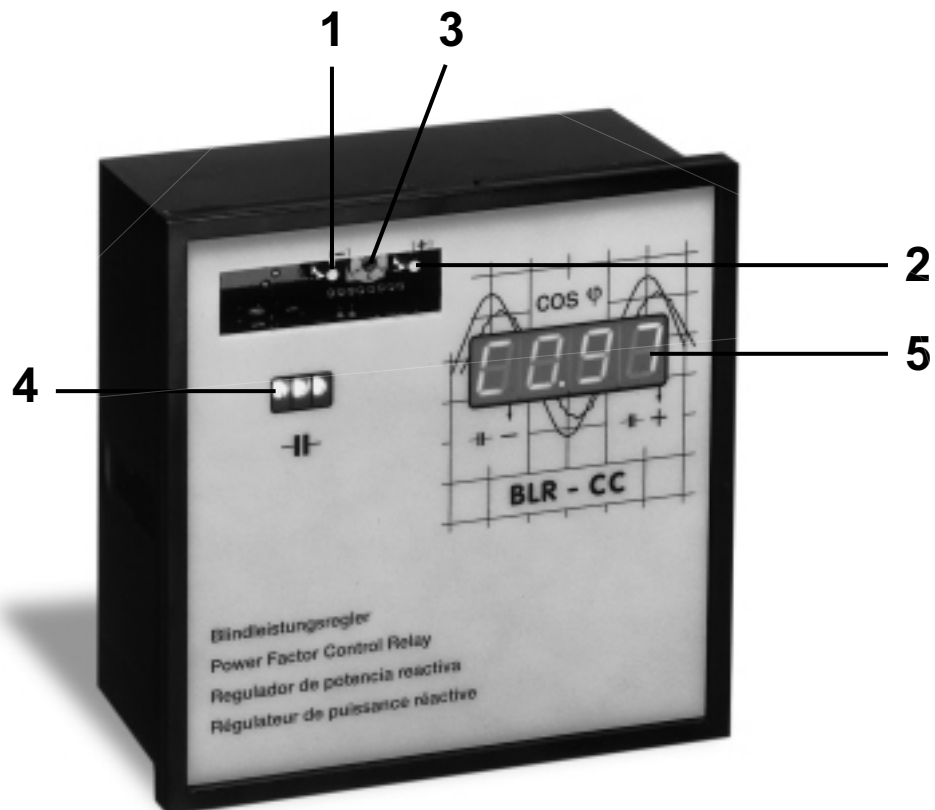

Technical Data:

Measuring Voltage:	Single phase electronic measurement system for connection to phase-phase voltage, 380-415 V. Voltage supply burden 7 VA max. - according to the number of steps switched in. Different voltages on demand. Operating frequency 50-60 cps.
Current Transformer:	5 A (1A on demand); Class 1 to 3; burden 1.4 VA.
Measurement System:	Measurement system operates in all four quadrants and analyses non-sinusoidal voltage and current waveforms.
Switch Rating:	2400 VA / 250 VAC per contact (energizing); 1200 VA / 250 V (hold); 415 V available on request.
Target Power Factor:	Adjustable from 0.70 lag. ... 1.0 ... 0.90 lead.
Switching Time Delay:	Adjustable from 5 ... 1200 sec.
No-Volt Release:	Automatic disconnection of all capacitors following voltage failure after only 35 msec. Automatic switching will recommence 90 seconds after restoration of supply.
Hand Operation:	By means of +/- push buttons.
Ambient Temperature:	- 10 ° C ... + 70 ° C.
Manufacturing Specifications:	Insulation protection in accordance with VDE 0160; creepage air paths in accordance with VDE 0110, group C; type tested; EMV guidelines 89/336/EEC; CE identification mark 93/68/EEC; UL, cUL 1997 and CSA certification. Instrument casing 144x144 mm; Total depth including plug 62 mm; flame retardant to 94 V-O.
Casing:	
Mounting Position:	As required.
Protection:	IP 50 (facia); IP 30 (casing).
Weight:	0.85 kg.
Connections:	Plug-in terminal block.
Indication:	For Power Factor cos ϕ and preset parameters.

Optional Features:

Fault Signalling Relay (m):	Operates when the digital display alarm "AL" is triggered. In the event of a fault in the relay, the contact (MO) will close, e.g. target power factor not obtained! Volt-free contact 1500 VA/250 V AC.
------------------------------------	--

Connection Diagram:

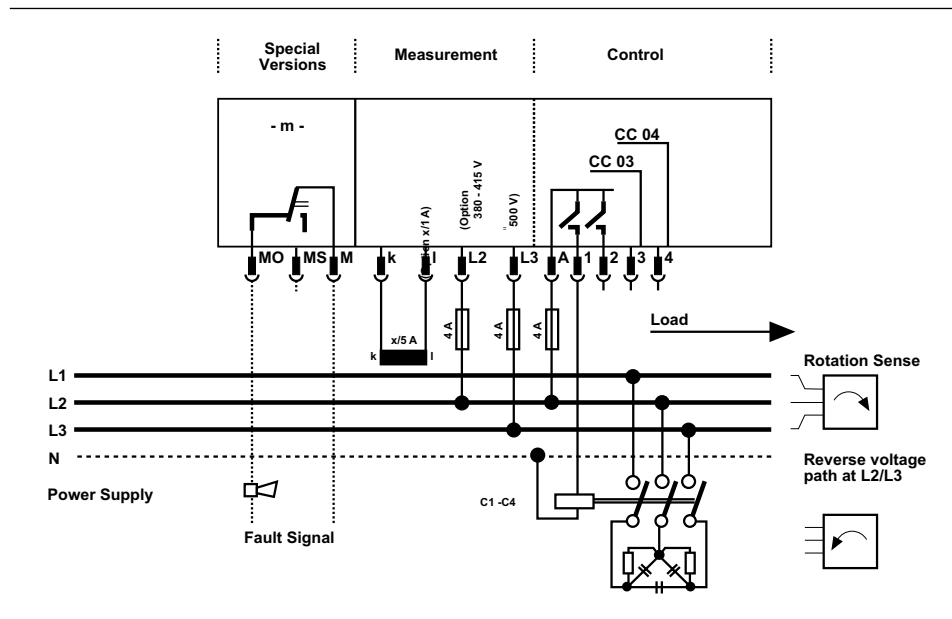

ILLIMITE IS YOUR HEADQUARTERS FOR ALL BELUK POWER FACTOR CONTROLLERS!

ILLIMITE
inc TOOLS FOR TECHNOLOGY

ILLIMITE INCORPORATED
P. O. Box 876
LOCKPORT, NY 14095
tel: 716 - 439 - 8600
fax: 716 - 439 - 9474

WWW.ILLIMITE.COM
INFO@ILLIMITE.COM

