

Operating & Commissioning Instructions BLR-CA

As with all electrical equipment, the appropriate specifications governing electrical installation must be followed when Power Factor Correction Equipment is installed. When removing the front nameplate to adjust the function switch and DIP switches, always ensure that your body is not carrying any electrostatic charge. This can be accomplished by simply touching a grounded object, such as the switchboard metal casing to dissipate any electrical charge before removing the cover plate.

1. Check that the Measurement and Control Voltage, Supply Frequency and Current Transformer rating comply with the ratings given on the back of the relay.

2. Mount the relay in the switch panel. The cut out size is 138x138 mm. The relay is secured with two fixing bolts

3. Connect up in accordance with the wiring diagram. **Pay special attention to the cross section size of the C.T. connections. We recommend for runs up to 10 metres 2,5 mm² cross section.**

An integrated voltage observation in BLR-C. guarantees a safety-disconnection of the capacitors in case of decreasing voltage below 70% AC. It is due to this device necessary to connect terminal "A" for control voltage to **L2** as shown in wiring diagram. This ensures a proper disconnection of the contactors.

4. Check that transformer current setting at coding switch (**S1**) is correct - OFF = $x/1A$ - ON = $x/5A$.

5. Adjust DIP switch (**S2**) to select p.f. Alarm function ON (in circuit) or OFF (out of circuit).

6. Apply the measurement and control voltages. Connect the Current Transformer, and remove any short circuit link. Indication "I -0": no current flowing, resp. <1% of nominal secondary c.t. current. Active steps are cut off automatically after 10 minutes. There is no cutoff if the system is operated manually. Any p.f. controlling starts, if reactive vector exceeds >1% of nominal secondary c.t. current at least.

7. Function switch (**3**) in position 3 = automatic operation

Required target p.f. = 1, switching time = 40s and step limitation are factory-preset. Wait for the 90 sec. lockout time to elapse. During this time the required parameters can be set as listed below, using the +/- buttons (4/5). Each set value is stored in the memory, once the function switch is moved on to the next position.

8. With function switch (3) in **position 1**, select the required target p.f. using +/- buttons.

9. With function switch (3) in **position 2**, select the required switching step time delay, using +/- buttons.

10. With function switch in **position 5**, select the number of switching steps, using the +/- buttons. The relay is delivered with this setting on its maximum number of steps. If the max. number of steps is selected, but capacitors are not connected to all the steps, the relay will recognize this, and will make three switchings to verify there is no connection. The disconnected step(s) will then be excluded from the switching sequence process. With function switch in **position 6**, the number of disconnected or defective steps will be shown. After 7 days, a system power failure, or deletion of the values with the function switch in position 6 (using +/- buttons >20s), the disconnected steps will be automatically reactivated and a renewed switching attempt will be made.

11. **Set function switch (3) in position 3, so that the installation is in "Automatic" operation.**

12. The digital indicator will show the system power factor.
f.e. 0.87 for lagging or 0.94 for leading load.

13. After the lock out time, with an inductive load on the system, if the relay is correctly connected, the + LED will start to flash.

14. If the installation is correctly connected, the relay will now switch successive steps, following the selected step time delay until the target power factor is obtained. Each energized step will be indicated on the LED display **6**. As each step switches in, so the digital display of power factor will change. If the installation p.f. is above or below the target p.f., the "+" LED (Below Target) or "-" LED (Above Target) will flash.

15. The BLR-CA does not require any adjustment of the responsiveness. Regulation does not follow a fixed switching program, different capacitor sizes can be used for the respective steps. The relay measures the output for each capacitor step in the form of "units of value" (inquiry in **position 8**). This measurement is made during the normal switching function according to reactive load requirement. These "units of value" are stored in the relay memory and the appropriate unit is

called up in order to meet the changing reactive load demand. As the current transformer transmission is unknown, the measured units of value are only proportional to the capacitor output. If capacitors of the same size in even distribution of the switchings is paid attention to.



16. A flashing display segment indicates that the relay is searching for a suitable capacitor size (in order to meet the required target power factor. if no suitable size is available, then no switching will take place, and the segment will continue to flash until the target p.f. is obtained.

17. It is often necessary to commission an installation when there is no other load on the system. In this case, put the function switch (3) to **position 4**. Capacitors can be switched with the aid of the +/- buttons. Please take into account that, during this time, there is not measured the output for each capacitor step in form of "units of value" (see item 15).

When manual operation is not required any more, set the function switch back to position 3 (Automatic).

18. With the function switch in **position 9** two storage types of alarm indication can be selected: the visual display is standard, external output (m) is carried out optionally by means of contacts at zero potential (see diagram).

a) With "**A_0**" in the display, the alarm indication can only be cancelled or reset by moving **DIP switch (2)** briefly into the off position (down).

b) With "**A_1**" in the display the alarm indication will be automatically cancelled once the correct target power factor has been obtained again.

c) If the target power factor is not obtained, on account of insufficient or defective capacitors, after a time delay of 75 times step switching time, the symbol "**AL_**" will appear at 5 sec. intervals in the display.

d) If the capacitors are being subjected to a distorted waveform which is producing dangerous harmonic overcurrents, then this will be shown as an alarm in the display: "**HA_**" will flash at 5 second intervals.

e) If both alarms are signalling together, then the symbols "**AH_**" will flash in the display.

f) If external fault signalling contacts for power factor (**m**) are fitted the alarm contact is given between terminals **M-MR (AL or AH)**.

g) At CA-regulators with external alarm-contact, option "z" or "L", contact via terminal M - MZ will close (display indicates either HA or AH).

19; Option **L**; control of ventilator: (Please note: At this option no harmonic alarm device is possible! See item 18/d). Ventilation control will be activated, if DIP switch S2 (behind removable name plate on front facia) is in ON position. Presetting automatic alarm reset in position **1**, selectable at multifunction switch in position HEX 9). DIP-switches S3+S4 enable to select 4 temperature threshold levels (see code-switches). If temperature increases the selected threshold level longer than 24s within a "time-window" of 8 minutes, contact via terminal **M-MZ** (230VAC/5A) closes for further 8 minutes at least. "**AH_**" (Alarm-Heat will be displayed).

Contact opens again automatically, if within next "time-window" of 8 minutes the temperature will not exceed the selected level once more, means plant had been cooled down. Any further exceeding of temperature will retrigger ventilation control automatically.

20; Exit port (7), TTL interface, enable data transfer to a PC by means of cable number 6. By means of software "BSTO" it is possible to record and analyze data, such as power factor $\cos\phi$, switchings, date and time of each switching step, connected and disconnected steps and any triggered alarm function. By means of the data storage DS21/22 or 23 it is possible to store data over a substantial period of time.

Once the required settings or alterations have been made, set the function switch to position 3 "Automatic" and replace the front cover plate, so as to inhibit unauthorized interference with relay settings.

DIP Switch (S1)

Current path: x/1A or x/5A
switch position OFF = x/1A
ON = x/5A

**check before
commissioning**

If requested data are not indicated on order, the relay will be shipped with DIP Switch in position "ON" (x/5A) !

DIP Switch (S2)

Alarm status messages (refer to point 18)

switch position OFF = alarm status messages off and/or alarm reset (Option -L- = Ventilation-Control OFF)
ON = alarm status messages on (Option -L- = Ventilation-Control ON)

DIP Switches (S3 +S4) (present at option- **L** , only)

Preset of temperature levels for ventilation control – see item 19

S3 – off / S4 off = **35°** // S3 – on / S4 off = **40°** // S3 – off / S4 on = **45°** // S3 – on / S4 on = **50°** C trigger levels

Function Switch (3)

(Standard Version with 10 Switch Positions)

0 = Relay not in automatic function. All steps will be switched off after 20 secs. The digital display will show "**OFF**".

1 = Adjustment of pre-set target power factor within the range 0,70 lag ...1,0 ... 0,90 lead. by means of the +/- buttons. Target level is shown in the display.

2 = Adjustment of the step switching time, 5 secs ... 1200 secs, by means of the +/- buttons. For rapid digit change, hold the button down continuously. The display will show for example "50".

3 = Relay in automatic function, with indication of system power factor in the digital display, i - ind., c = cap. If the +/- segments are flashing, this indicates that the target power factor has not been achieved. A suitable capacitor size will be selected.

4 = Manual operation. The display will show alternately "**H**" (1sec) and Power Factor (5 secs). Capacitor steps can be switched in rotation after the selected step switch time, using the +/- buttons.

5 = The number of switching steps can be limited, using +/- buttons. The display will indicate the number of steps - e.g. for 10 steps "CL10". **Do not exceed the number of steps on the relay!**

6 = Automatic indication in the display of the number of steps which are not connected or are not working. The indication will rotate through the non-functioning steps, e.g. "Cd 5" = 5 non-functioning step. Display "Cd 0" means that all steps are functioning. Automatic regulation is active during this time (CD = capacitor defective)! Any failed capacitor step will be displayed with letters "AL" alternating with cos phi indication. The indication of defective steps can be cancelled by pressing the +/- buttons **together** for a period > 20 secs. Automatic regulation is active during this time!

7 = The number of switching each contactor has made is shown in the display, e.g. "OC 4" for 2 secs., then "**248**". This indicates that contactor no. 4 has completed 248 switchings. Other contactors can be selected using the +/- buttons. Only every 50 switchings, the microprocessor stores the data. The stored data of all steps can be cancelled by depressing the +/- buttons **together**, for a period of > 20 secs. Automatic regulation is active during this time!

8 = Indicates the measured "unit of value" of each step, which is proportional to the capacitor output in kVAr. For example, the display will show "CC 12" for 2 secs., to indicate step No. 12., and will then alternate to "125" units of value. Once the value falls below a level of < "8", the capacitor will be excluded from the regulation process. The "unit of value" for other steps is obtained by depressing the + or- buttons to select the required steps. The stored data of all steps can be cancelled by depressing +/- buttons **together** for a period > 20 secs. This starts a redefinition of the capacitor outputs. Automatic regulation is active during this time! (CC=Capacitor capacity)

9 = Selects the mode of alarm signal required. If the display shows "A 0", the alarm is stored in the memory and can only be cancelled by briefly switching DIP switch (**S2**) off. If the display shows "A 1", the alarm will be cancelled automatically, when the target power factor level is restored (Selection by means of +/- buttons). Any reset at option "**L**" will be triggered after a passed "time window" of 8 minutes only.

If requested data are not indicated on order, the relay will be shipped in "A 1" mode!

B = Input for assymetrical switching times. Using the +/- buttons, this can be adjusted between 0 ... 50. For example, if the display shows "Y" 10" the factor displayed will multiply the switching off time in the capacitive direction. (Rapid switching on - slow switch off). The standard setting with equal switch on/off times is "Y 0".

C = Rapid contactor switching rate limiter. By using the +/- buttons a time delay can be set in seconds so as, to prevent the rapid on/off switching of a contactor on a constantly changing load. The standard setting would be 30 secs. and the display would then show "L 30". The delay time can be set up to 255 secs.

D = no function

E = OFF. Same effect as function switch in Position **0** (see above).

F = Indication of Switching mode

"S CC" = Economy Switching (Connected capacitors have different sizes)

" CC" = Circular Switching (Connected capacitors have equal sizes)

Optional Setting Features

A = Input of alternative target power factor level for low tariff operation. Setting range 0,70 lag ... 1,0 ... 0,90 lead. The required target level is adjusted in the display using the +/- buttons. In order to activate this feature a supply voltage of 150-240 V AC 50/60Hz must be applied to P and N. This can be achieved by using a time switch, or impulse relay etc. LED (9) will illuminate if this feature is active.

Other:

- m- capacitor alarm message, external
- z- harmonic alarm, external
- e- single-phase measurement
- NT- 2nd cusp point (see point A)
- L - Fan-Control

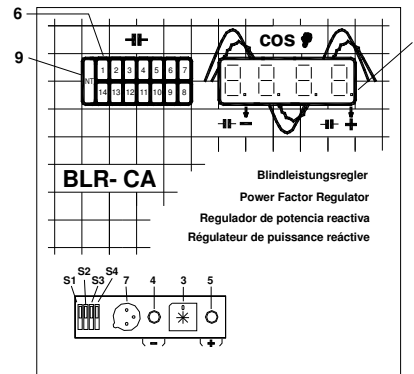
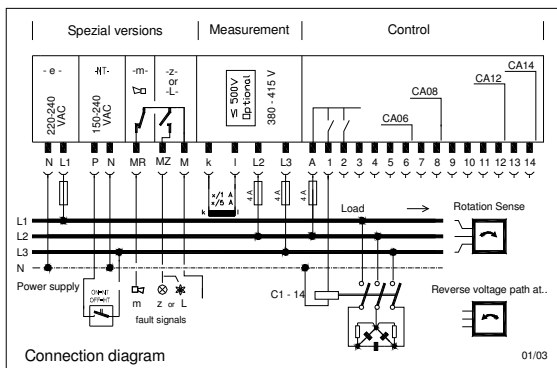

ILLIMITE
inc TOOLS FOR
TECHNOLOGY

ILLIMITE INC.
P.O. Box 876
LOCKPORT, NY 14095

email info@illimite.com
web www.illimite.com
tel: 716-439-8600
fax: 716-439-9474

